

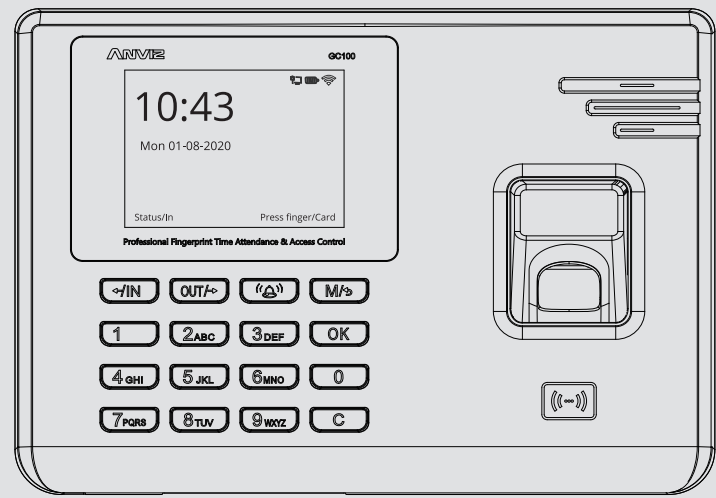

# GC100/GC150

Quick Guide V2.0



www.anviz.com

## 1. Packing list

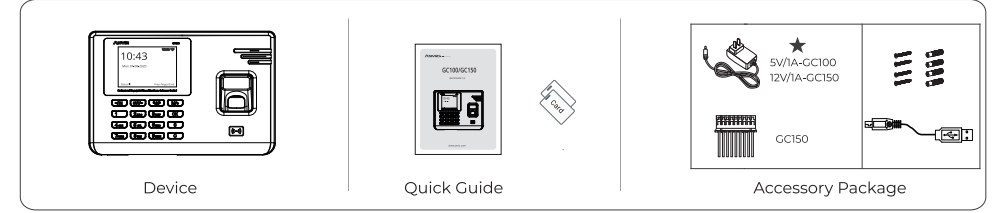

## 2. Installation Diagram&Installation Step



## 3. Interface Description

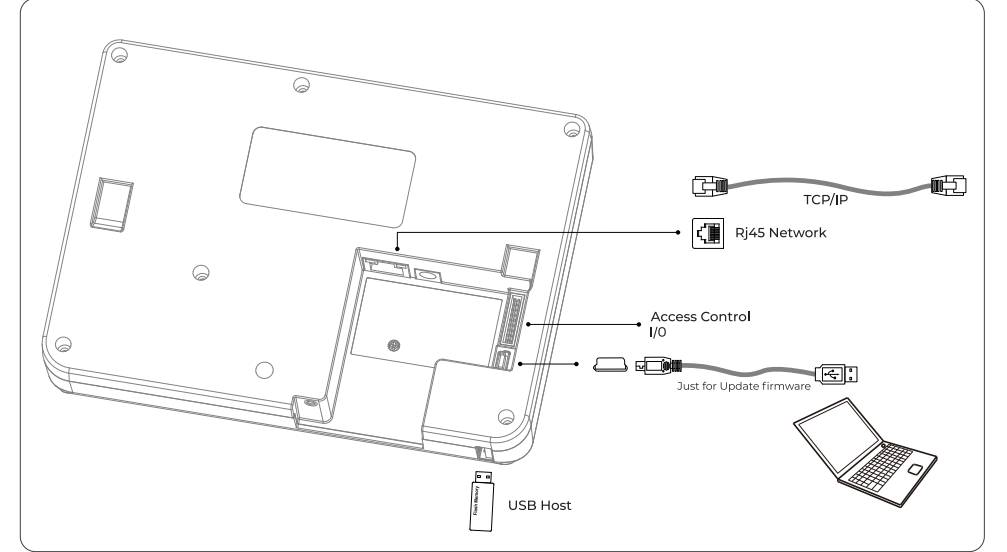

## G150 Interface Description

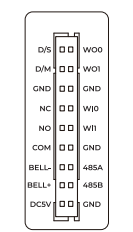
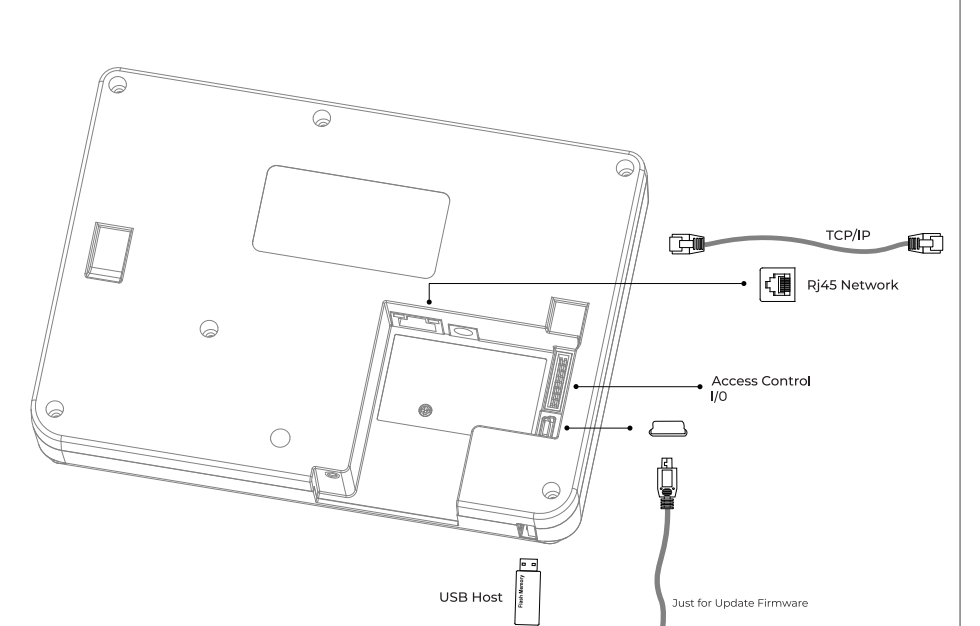

**Important Notice**

Please follow the wiring diagram as it is displayed. Damaged products due to improper wiring are not covered under the product warranty.

## 4.GC100& GC150 Wiring

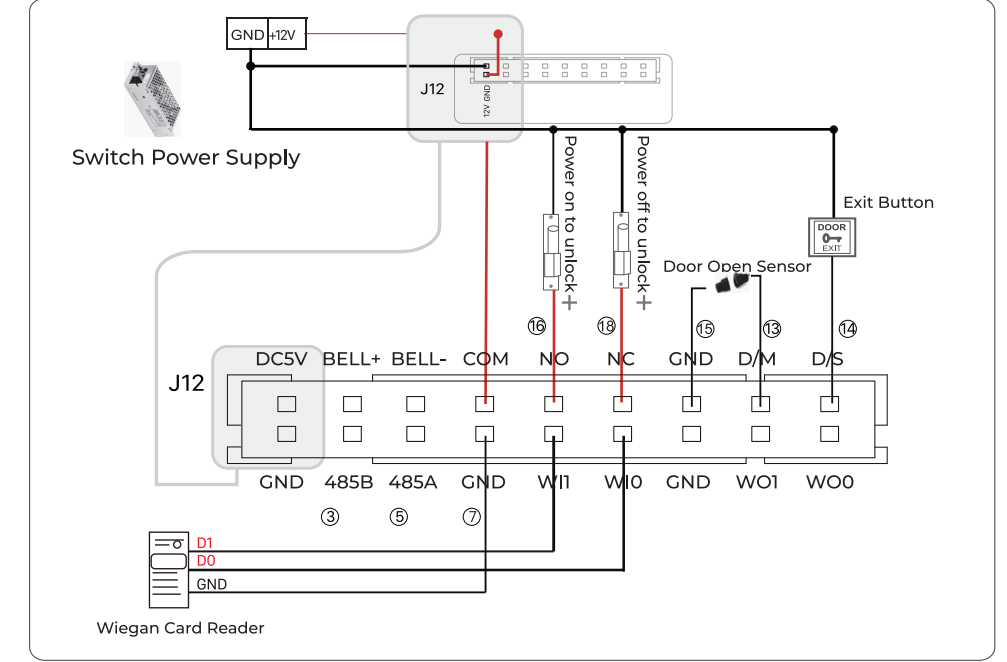

## 5. GC100 & GC150& Anviz SC011

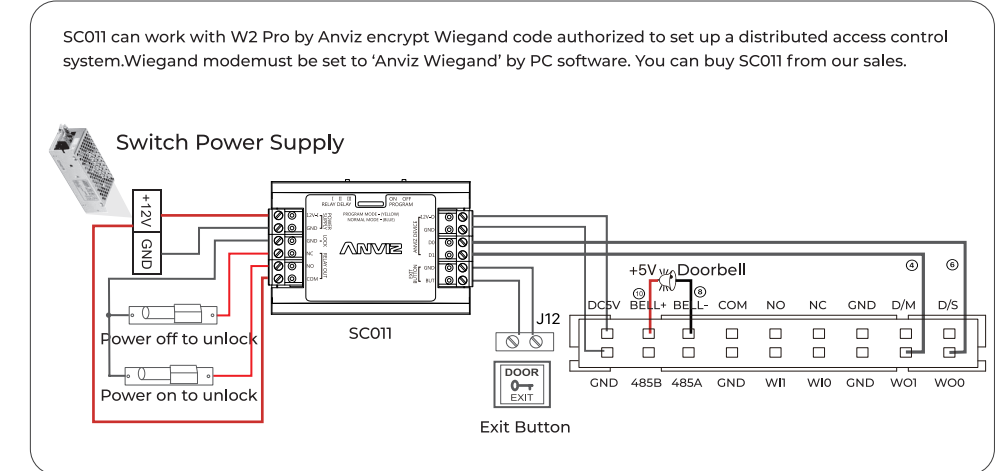

## 5. W2 Pro & Access Control Power Supply

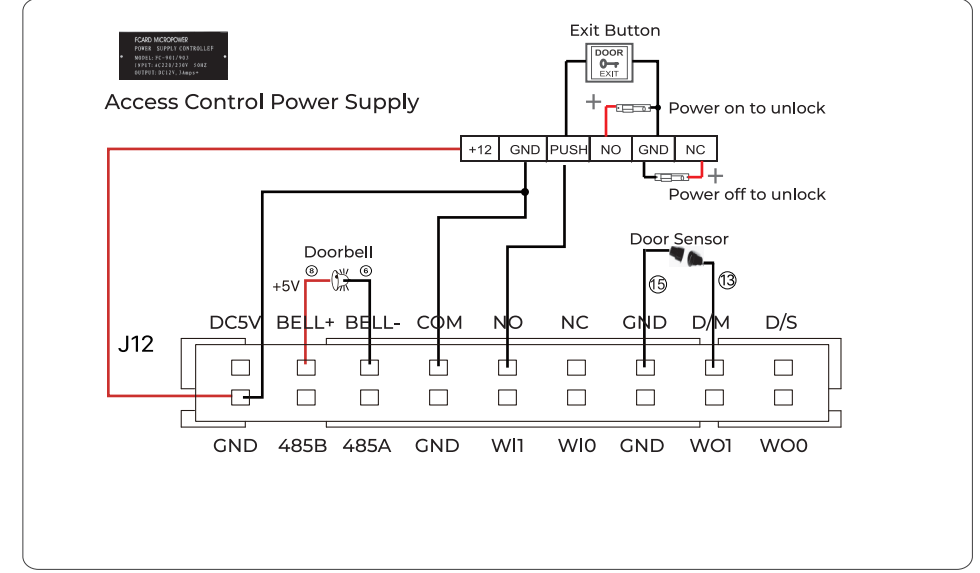

## 7. Operation Guide

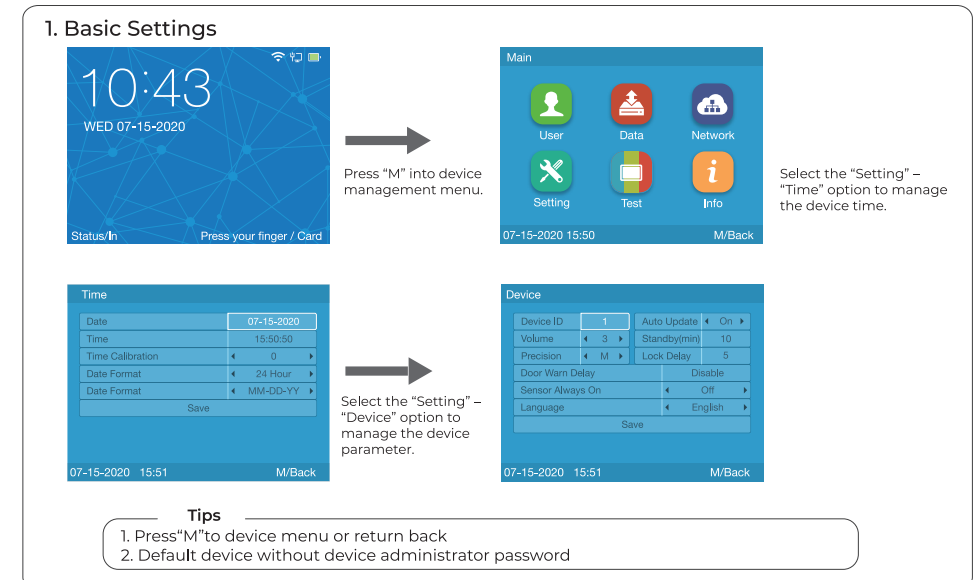



In order to protect the environment, Anviz has decided to go "CD Free" campaign since June 1st 2019. We will provide QR code for you to download the electronic documents to make sure that you understand how to install and use Anviz devices.



<https://bit.ly/2WugbYp>

Dropbox



<https://bit.ly/2Vn0wh6>

Google



<https://bit.ly/2J9qA95>

Anviz

Anviz brand and product are trademarked and protected under law of the United States. Unauthorized use is prohibited. For more information, please visit [www.anviz.com](http://www.anviz.com), or send email to [sales@anviz.com](mailto:sales@anviz.com) for more help. ©2020 Anviz Global inc. All Rights Reserved.

## 2. Add Users

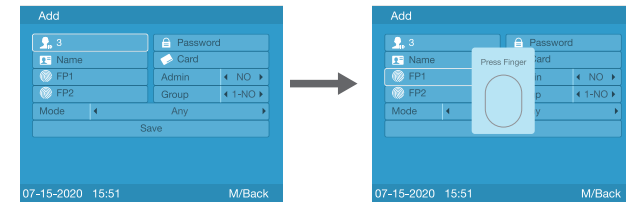

Select "User"----"Add" option to enroll user.

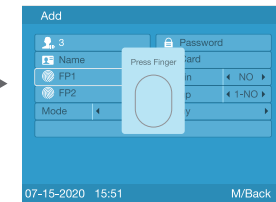

Select the "FP/Card/Password" to enroll user verification mode and click "Save" to keep user enroll.

## 3. Verity the Fingerprint

### • Correct Method:

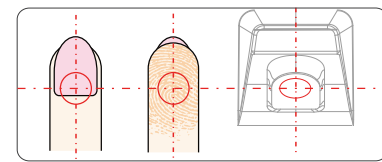

Place finger in the center of the sensor.

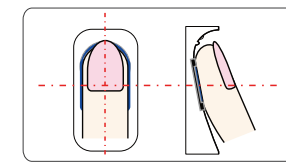

Place finger flatly and smoothly on the sensor.

### • Incorrect Method:

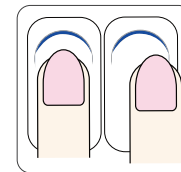

Finger not placed on the center of the sensor.



Finger placed inclined.

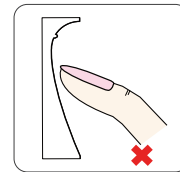

Use of fingertip.

## 4. Character Input Method

When you need to edit your name, you need to enter characters. Here are the steps for entering characters:

- Use the left and right move keys to move the cursor to the area you want to edit.
- Press the [Fn] key on the keyboard and a character input window "Aa" will be displayed at the bottom of the screen.
- Press [IN] on the keyboard, the letter window will switch between "Aa", "123" ",!?" and "Picture". you can select the window to enter letters, numbers, or special characters.

- Switch to Network\Internet menu, select Ethernet (Wi-Fi is optional).
- Switch to network\communication mode, select server or client mode.
- Switch to the network menu and set the Ethernet parameters according to your network environment.
- On the management computer, spell the IP address of GC100/GC150 to ensure that it can be worked together.
- When the device has Wi-Fi function, it is suggested that the device should be installed as far away from the metal parts as possible. The distance between the installation location of the device with Wi-Fi function and the router should be within 30m.

## 1. Wi-Fi Settings(Optional)



Select the "Network" -- "Wifi" option to connect with WIFI.

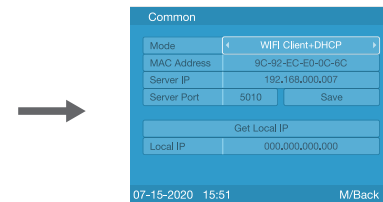

Select the "Network"----"Common" to setting WIFI communication parameter.

## 2. Ethernet Settings

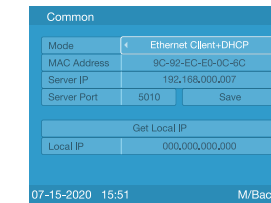

Select the "Network" -- "Common" to setting the device Ethernet parameter.

## 9. Working with Management Software

1. Working with Management Software Scan the QR code on user manual to install the software.

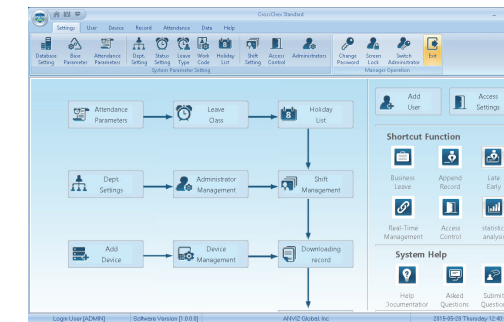

## How to connect the Device with Software? Connect to Network

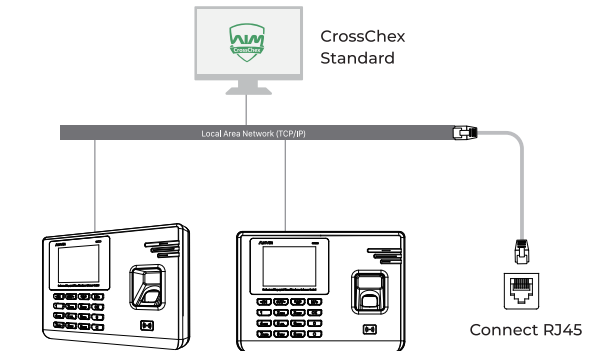

## 2. Enable Communication between Device and the Management Software CrossChex

- Turn on management software CrossChex.
- Go to Device tab. Search and Add the device to management software CrossChex.
- Click Synchronize Time button to communicate with Device. If Synchronize is successful, the device icon will turn to blue.

## 3. The Management Software CrossChex Features

- Device\Backup User: Download user info from Device to CrossChex.
- Device\Download Records: Download records from Device to CrossChex.
- User\Modify: Edit name or other user info. Then click "Upload User" to Upload user info to device.
- Record\Search: Search and view the records.
- Attendance: Calculate, Search results and Generate reports.
- Data\Backup Database: Backup Database.
- Setting\Shift: Set up Time Table and Scheduling.
- Device\Device Parameter: Set up device. Clear records on Device or Reset Device to factory settings.